

DUALFRAME

WINDOW WALLING

TECHNICAL
DATA





DUALFRAME

INTELLIGENT DESIGN:

The Sapa Dualframe range is designed to comply with Building Regulations, British Standards and other regulatory demands.

SUPERIOR THERMAL PERFORMANCE:

Dualframe can meet the requirements of Part L of the Building Regulations for both thermal insulation and air permeability, and has been designed to be compliant with future anticipated changes. Where required, Dualframe 75 casement can achieve an 'A' Window Energy Rating.

DUAL COLOUR CAPABILITY:

All Dualframe products can have differing finishes internally and externally.

WINDOW WALL:

Dualframe Window Wall is designed to offer a cost effective alternative to curtain walling and is the ideal solution for projects featuring large runs of glazing. Easy to install it can be preassembled off site to minimise costs and time. Window wall is simple to glaze and re-glaze making it ideal for schools and public buildings.

ACCREDITATION:

Dualframe casement windows have been awarded BSI Kitemarks to BS4873 'Specification for aluminium alloy windows' and to meet Secured by Design Specification for enhanced security performance of casement windows for domestic applications.

CHOICE OF APPEARANCE:

Chamfered and Softline profiles are available to many products within the Dualframe suite, options of internal or external beading (including PAS 24 compliant security) are also available.

EASE OF MAINTENANCE:

The integration of a 'Eurogroove' features enables use of multi-point and shootbolt locking hardware, ensuring the product is competitive and easily maintained.

PRODUCT

Dualframe 75mm outward opening side and top hung casement windows

DESIGN VARIANTS

Can be constructed to form fixed and opening lights either as combination frames or as separate coupled lights.

COMPATIBILITY

Can also be integrated with other products from the Sapa range .

APPLICATION

Suitable for installation in new build or replacement projects in residential, commercial or public buildings.

FINISHES

A wide range of polyester powder coat finishes is available to BS EN 12206:1 2004. Anodised finishes are to BS 3987 Grade AA25 etch silver with a range of special anodised finishes on application.

For more details, or to talk to a Project Consultant, contact Lead Management on 01684 853500.

DUALFRAME

COMPOSITION AND MANUFACTURE

Aluminium profiles are extruded from aluminium alloy 6063 or 6060 T6 complying with the recommendations of BS EN 755- 9.

Weatherstripping is polypropylene backed woven pile and polyurethane foam enclosed in a polythene sheath or fully gasketed, set in undercut grooves in the sash and the outer frame.

The thermal barrier section is achieved using two separate aluminium extrusions and two polyamide extrusions mechanically jointed to form a single compound profile.

Frame members are mitre cut at 45 degrees. Corners are reinforced with stainless steel corner ties and extruded aluminium corner cleats. All joints are sealed against water entry during fabrication.

GLAZING

Drainage in accordance with details listed in the Product Manual meets the requirements of 'Ventilated and Drained Glazing System', as specified in BS6262. Insulating glass units of 24mm up to 32mm can be accommodated as standard, other depths can be accommodated on request.

Fixed/Opening Lights: Glass set against extruded synthetic rubber gaskets retained in undercut grooves within an aluminium bead profile. Final retention of the glass is achieved by the application of a wedge gasket between the inner face of the glass and the frame.

HARDWARE AND SECURITY

The Dualframe casement window is available as standard with a multi-point locking system, comprising rods moving in opposing directions, with opposing centre cam and end shootbolts operated by handles with key deadlocking.

Hinges as standard are stainless steel, projecting friction stays with optional restricted and egress variants.

Extruded aluminium butt hinges with stainless steel pins are available as an option.

Optional hinge protectors can be specified to be used when enhanced security to PAS 24 is required.

The Dualframe casement window system (in both externally and internally beaded formats), has been tested to PAS 24 and BS 4873, details upon request.

*Butt Hinges - Each hinge will carry a maximum of 20Kg in both side hung and top hung applications.

Where a top hung vent is hung from a transom, this figure should be reduced to 15Kg per hinge and the maximum width of the vent restricted to 1500mm.

These butt hinges are primarily designed for use with folding openers, remote operating gear or electronic actuators. Where they are fitted in conjunction with espag gear or cockspur handles, suitable friction restrictors must also be used.

Weatherbars are to be fitted over butt hinge opening lights, unless there is a soffit or similar to give protection. Therefore DF300 outerframe cannot be used where a soffit does not exist because the weatherbar cannot be fitted.

Other hardware specifications are available (eg for remote operation, trickle ventilators), consult Hydro Building Systems UK Ltd for details.

AUTHORITY

BS 4873: Aluminium alloy windows

BS 6375-1: Performance of windows: Classification for weathertightness and guidance on selection and specification.

BS 6375-2: Performance of windows. Specification for operation and strength characteristics.

PAS 24: Specification for enhanced security performance of casement and tilt/turn windows for domestic applications.

BS 6262: Code of practice for glazing for buildings.

BS EN 755-9: Aluminium and aluminium alloys. Extruded rod/bar, tube and profiles. Profiles, tolerances on dimension and form.

BS 3987: Specification for anodic oxide coatings on wrought aluminium for external architectural applications.

BS EN 12206:1 2004: Specification for powder organic coatings for application and stoving to aluminium alloy extrusions, sheet and perforated sections for external architectural purposes.

BS EN 10077-2: Thermal performance of windows, doors and shutters – Calculation of thermal transmittance – Part 2: Numerical method for frames.outerframe.



BSI Registered firm
Licence No. FM0114

DUALFRAME

THERMAL PERFORMANCE

Dualframe 75 can meet and surpass the area weighted average U values stipulated in Part L of the Building Regulations. Lower U-values can be achieved using enhanced double glazed units with specialist glass unit edge spacers.

U VALUES

Dualframe 75 can meet and surpass the area weighted average U values stipulated in Part L of the Building Regulations. Lower U-values can be achieved using enhanced double glazed units with specialist glass unit edge spacers.

WEATHER PERFORMANCE

When tested in accordance with BS 6375: Part 1, products manufactured, installed and glazed strictly to the details outlined in the Product Manual, can exceed exposure category '2400 Special'.

Water Tightness	600 Pascals(static test)
Air Permeability	600 Pascals
Wind Resistance	2400 Pascals*

* Exposure category varies with Width/Height of window and mullion/transom used, as these are the only unsupported members. An accurate figure can be obtained using calculations and the inertia values given in the Product Manual.

SIZE LIMITATIONS

All sizes given are in millimetres, all maximum sizes relate to the overall size of the vent frame and not the outerframe.

*See Page 5 Hardware and Security

** Minimum sizes can be reduced to 302mm when using Cockspur handles.

STANDARD CASEMENT - SIDE HUNG

Stay Size	8"	12"	16"	Butt Hinge
Max Width	400	600	700	700
Max Height	1200	1300	1300	1300
Max Weight	18kg	22kg	24kg	*
Min Width	302	358	601	*
Min Height	424**	424**	424**	424**

HEAVY DUTY CASEMENT - SIDE HUNG

Stay Size	10"	16"	Butt Hinge
Max Width	660	838	838
Max Height	1524	1829	1829
Max Weight	37kg	45kg	*
Min Width	302	661	*
Min Height	424**	424**	424**

STANDARD CASEMENT - TOP HUNG

Stay Size	6"	8"	10"	12"	16"	20"	24"	Butt Hinge
Max Width	1200	1200	1200	1200	1200	1200	1200	1200
Max Height	300	350	400	550	750	1000	1200	1200
Max Weight	10kg	12kg	16kg	20kg	21kg	24kg	35kg	*
Min Width	424**	424**	424**	424**	424**	424**	424**	424**
Min Height	250	301	351	401	551	751	1001	*

HEAVY DUTY CASEMENT - TOP HUNG

Stay Size	10"	16"	Butt Hinge
Max Width	660	838	838
Max Height	1524	1829	1829
Max Weight	37kg	45kg	*
Min Width	302	661	*
Min Height	424**	424**	424**

SUPPORT SERVICES/

PROJECT CONSULTANCY

Our field based Project Consultants, working with our in-house technical services department, provide UK specifiers with guidance concerning the correct application of products, giving guidance on Building Regulations, British Standards and other issues such as product specifications, usage, maintenance and safety. Complementary to this, our Product Support Department has an invaluable reservoir of experience on every aspect of our product range.

SPECIFICATION PROCESS

We also appreciate that the specification process is influenced by client demands to obtain best value, and to that end, we can participate in site visits, design meetings and budgetary planning. Design stages can be formalised through written specification documents (which can be supplied in either an NBS format, or your own specification layout) and supported by samples, literature and drawings for consultation or planning issues.

PARTNERSHIP APPROACH

Taking this partnership approach through the whole project allows on-site monitoring of manufacturing and installation ensuring the specifier always has professional support from a worldwide group. Drawing on one of the largest fabricator and installer networks in the UK, we can provide details of specialist contractors who will quote or tender competitively for any type of contract.

HYDRO

Hydro is a fully integrated aluminium company with 35,000 employees in 40 countries on all continents, combining local expertise, worldwide reach and unmatched capabilities in R&D.

In addition to the production of primary aluminium, rolled and extruded products and recycling, Hydro also extracts bauxite, refines alumina and generates energy to be the only 360° company of the global aluminium industry. Hydro is present within all market segments for aluminium, with sales and trading activities throughout the value chain serving more than 30,000 customers.

Our Technal, WICONA and Sapa brands develop and manufacture door, window and curtain walling systems. Through our globally renowned Technology Hubs, the group is shaping a sustainable future, with innovative products that satisfy and surpass customer expectations, in line with the demands of Corporate Social Responsibility and increasing environmental regulations. Hydro facilities in the UK provide direct access to extrusion and anodizing.

[For specification assistance or details of fabricators & installers, please 01684 853500.](tel:01684853500)

DUALFRAME

/GENERAL ARRANGEMENTS

JAMB/FLAT VENT

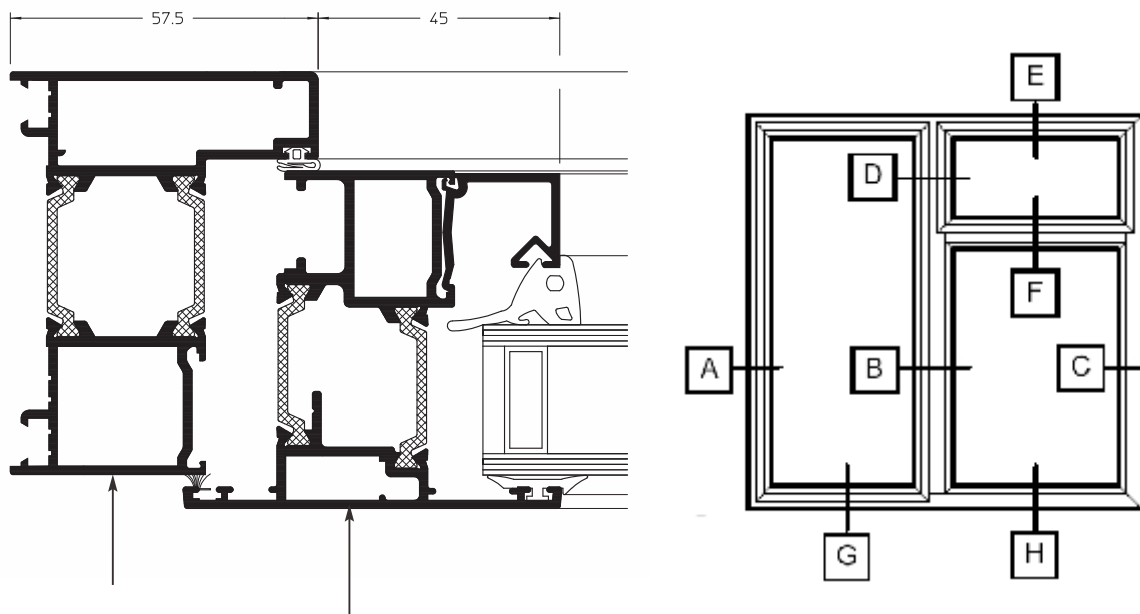

CURTAIN WALL JAMB/FLAT VENT

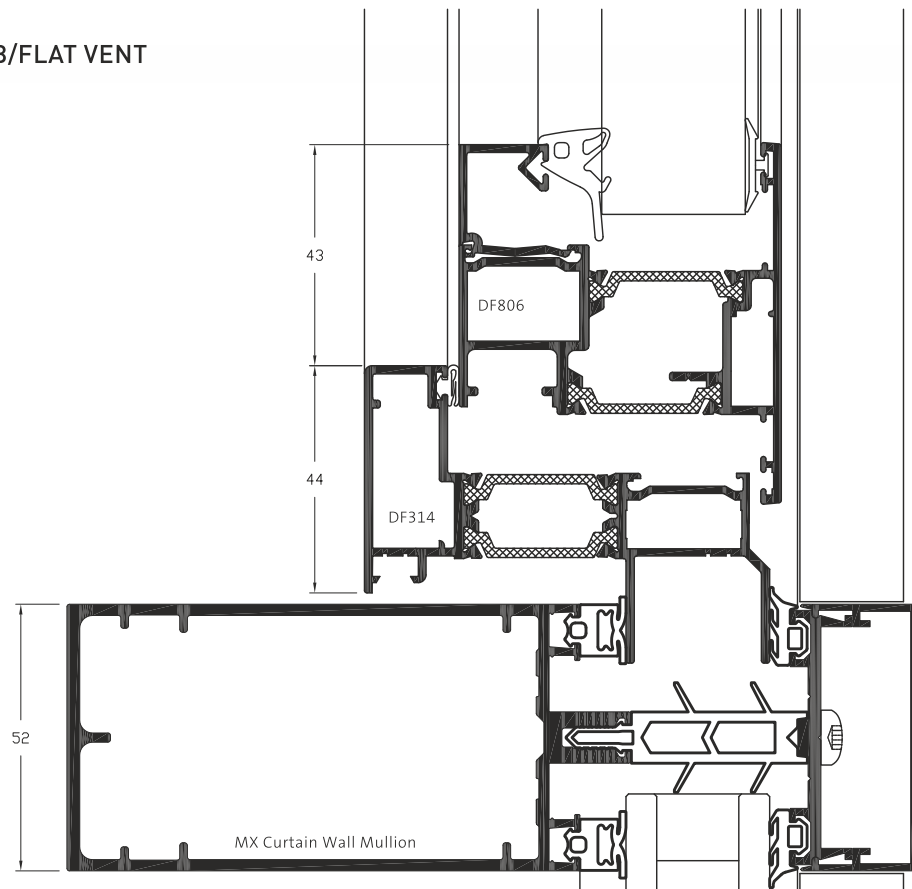

FIXED LIGHT JAMB

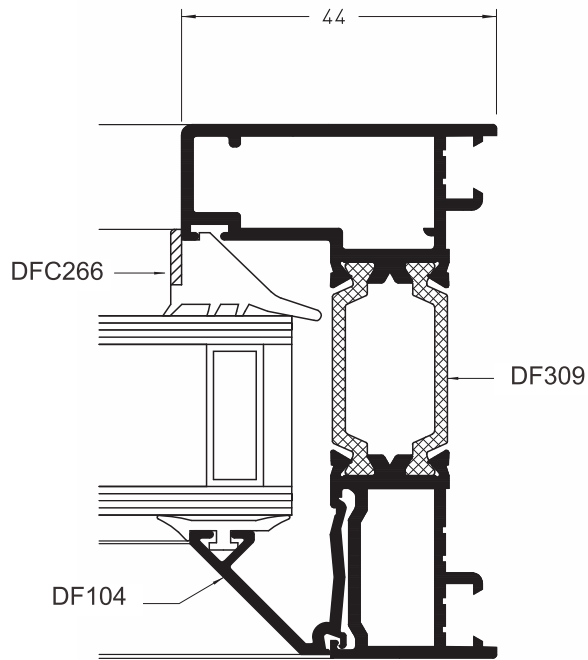

MULLION VENT/VENT

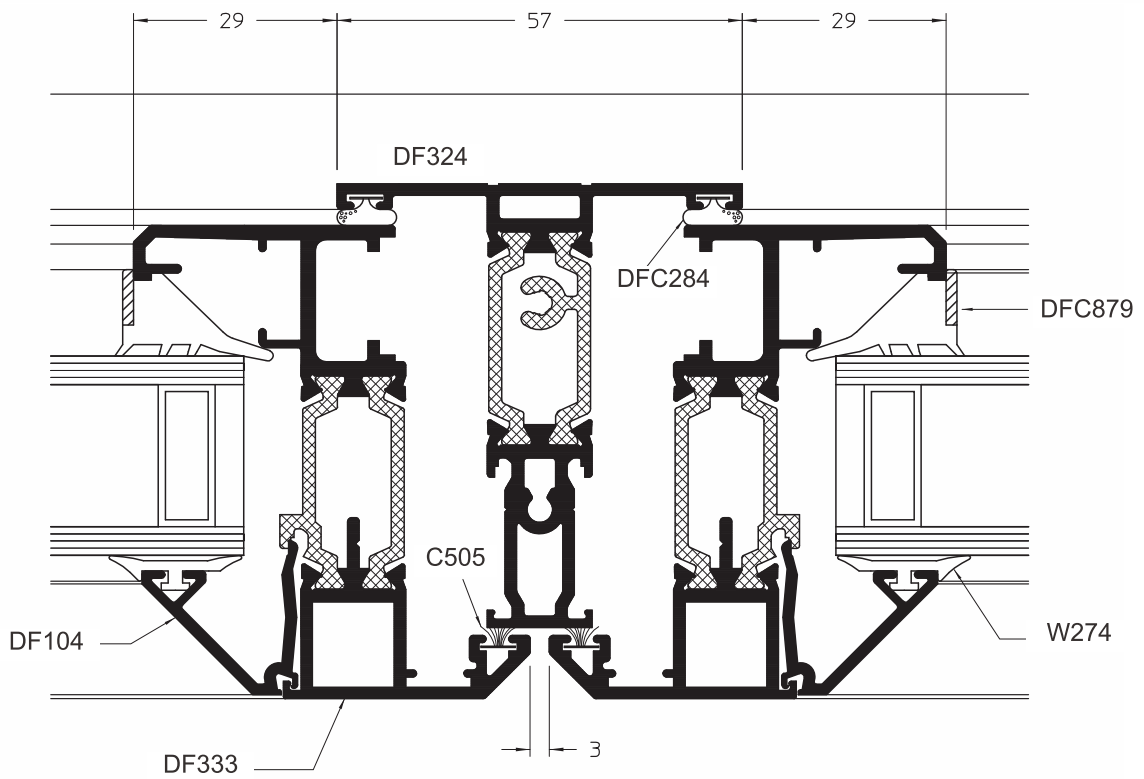

DUALFRAME

/GENERAL ARRANGEMENTS

HEAD/VENT

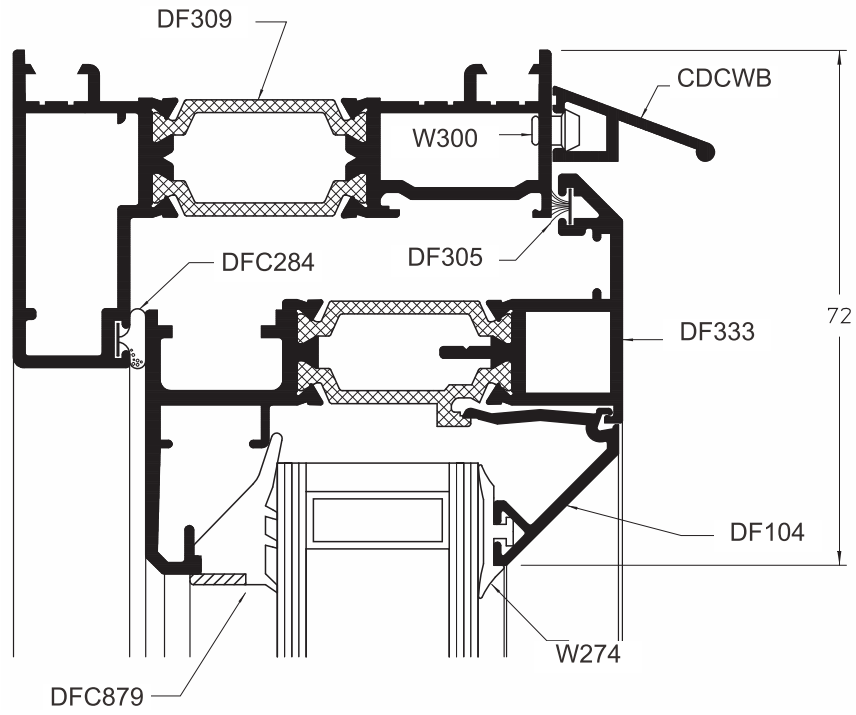

TRANSOM/VENT

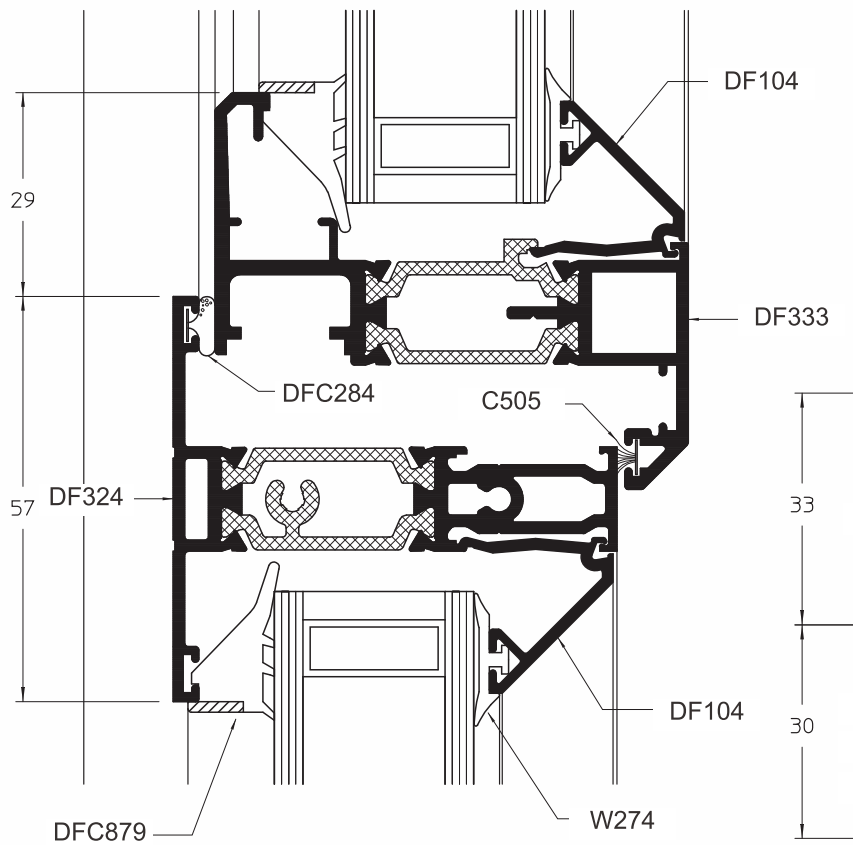

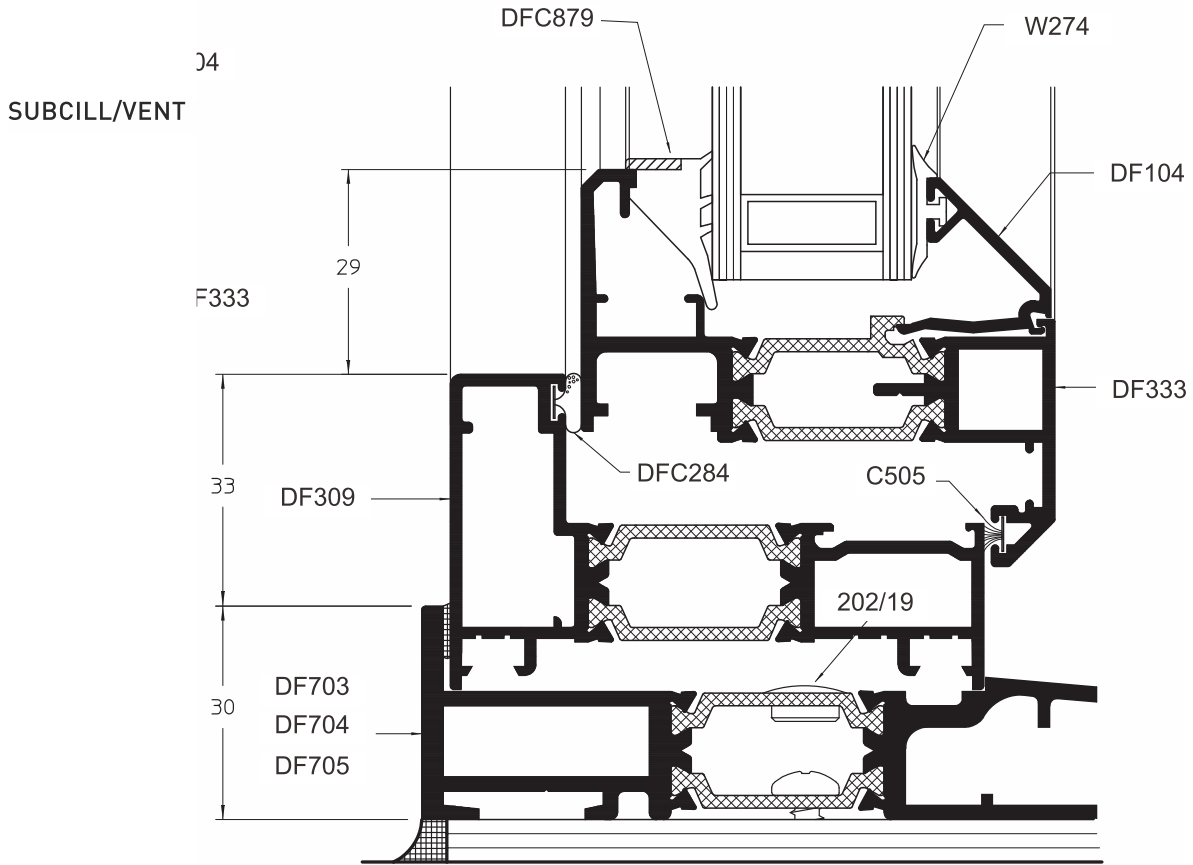

SUBCILL/FIXED LIGHT/SQUARE BEAD

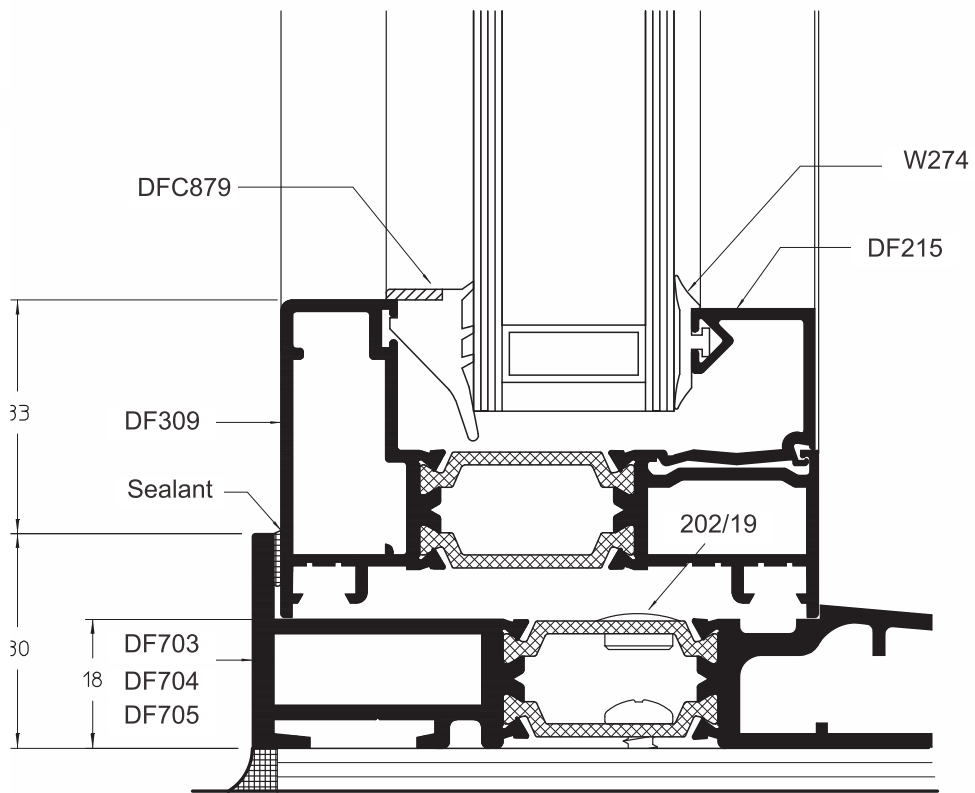

DUALFRAME

/GENERAL ARRANGEMENTS

DRAINAGE TRAY/FIXED LIGHT/SQUARE BEAD

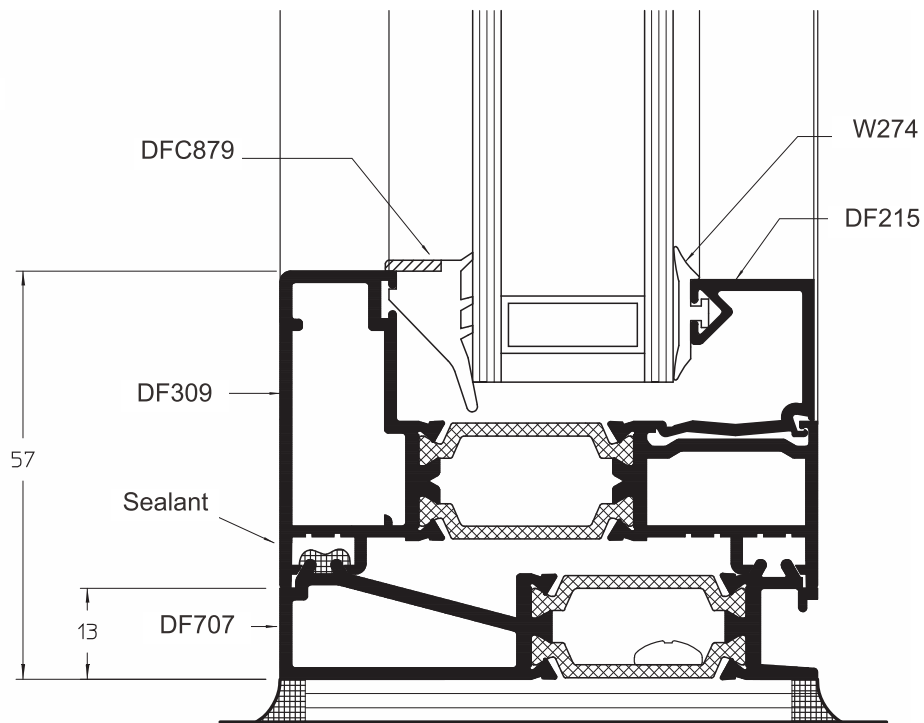

LIGHTWEIGHT CONCEALED FRAME TO FRAME COUPLER

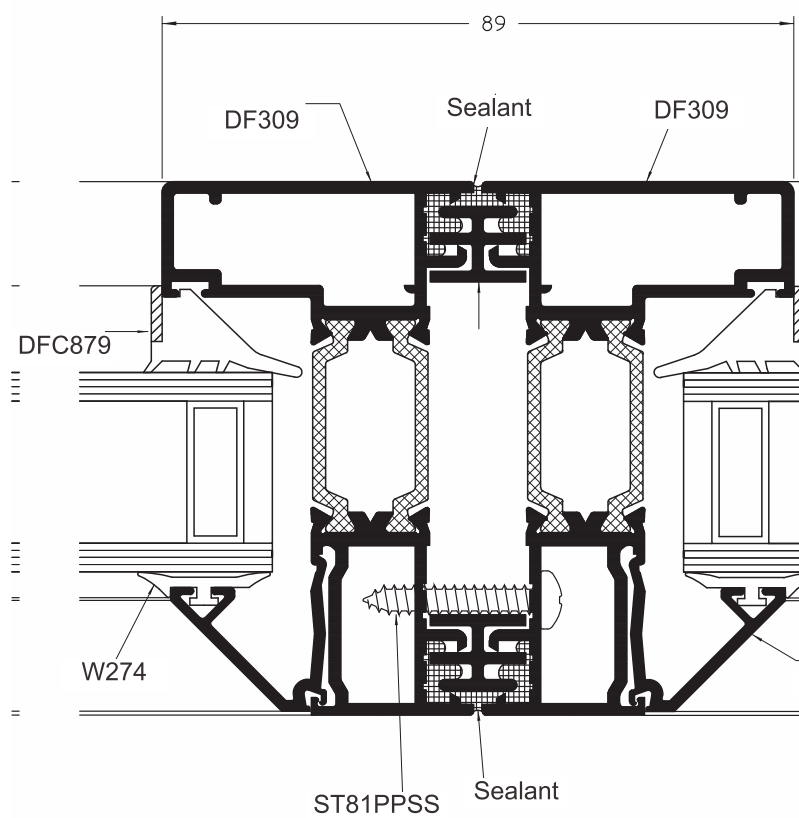

HEAVY DUTY COUPLING BOX MULLION

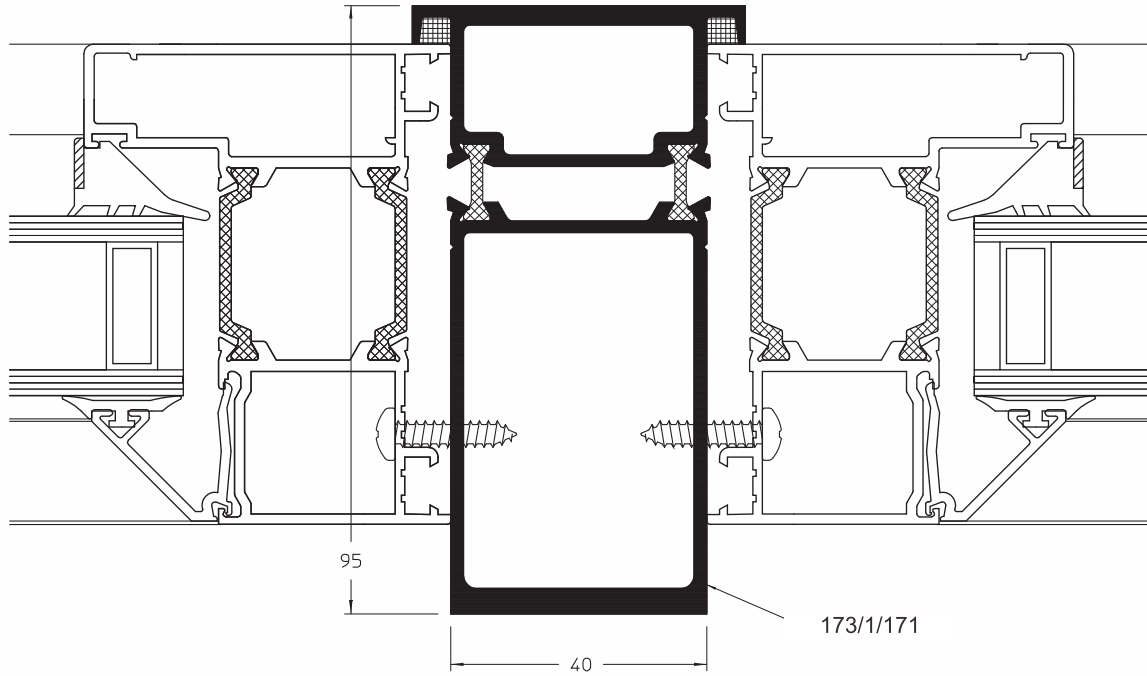

EXTENDED SQUARE OUTERFRAME AND CHAMFERED VENT

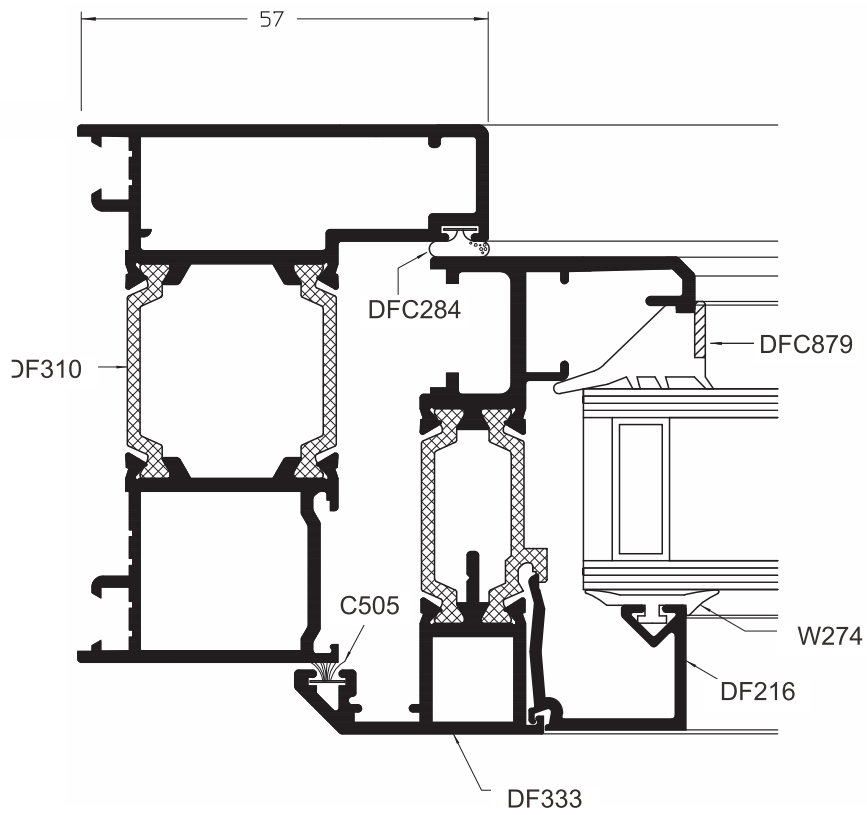

DUALFRAME

/GENERAL ARRANGEMENTS

CHAMFERED MULLION/TRANSOM

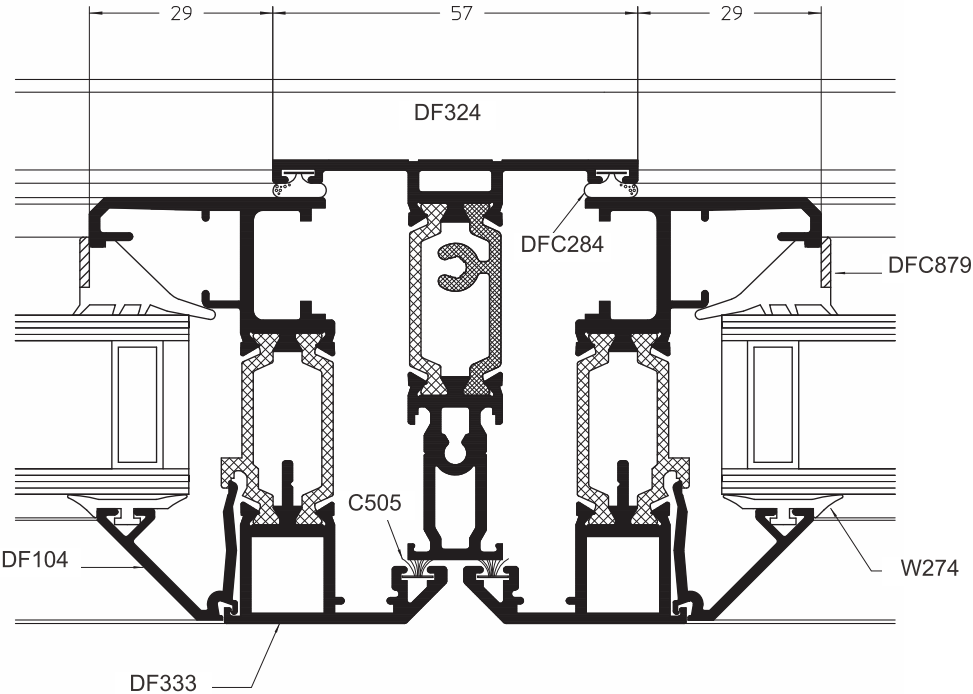

WIDE SQUARE MULLION/TRANSOM WITH VENT

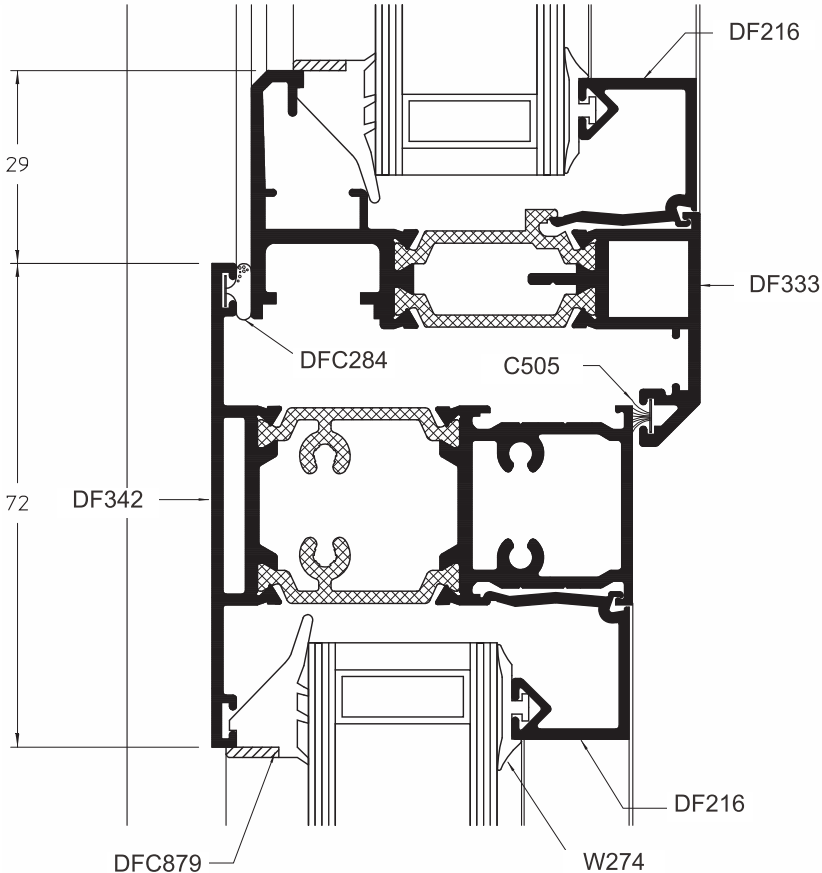

WIDE SQUARE TRANSOM WITH DRIP

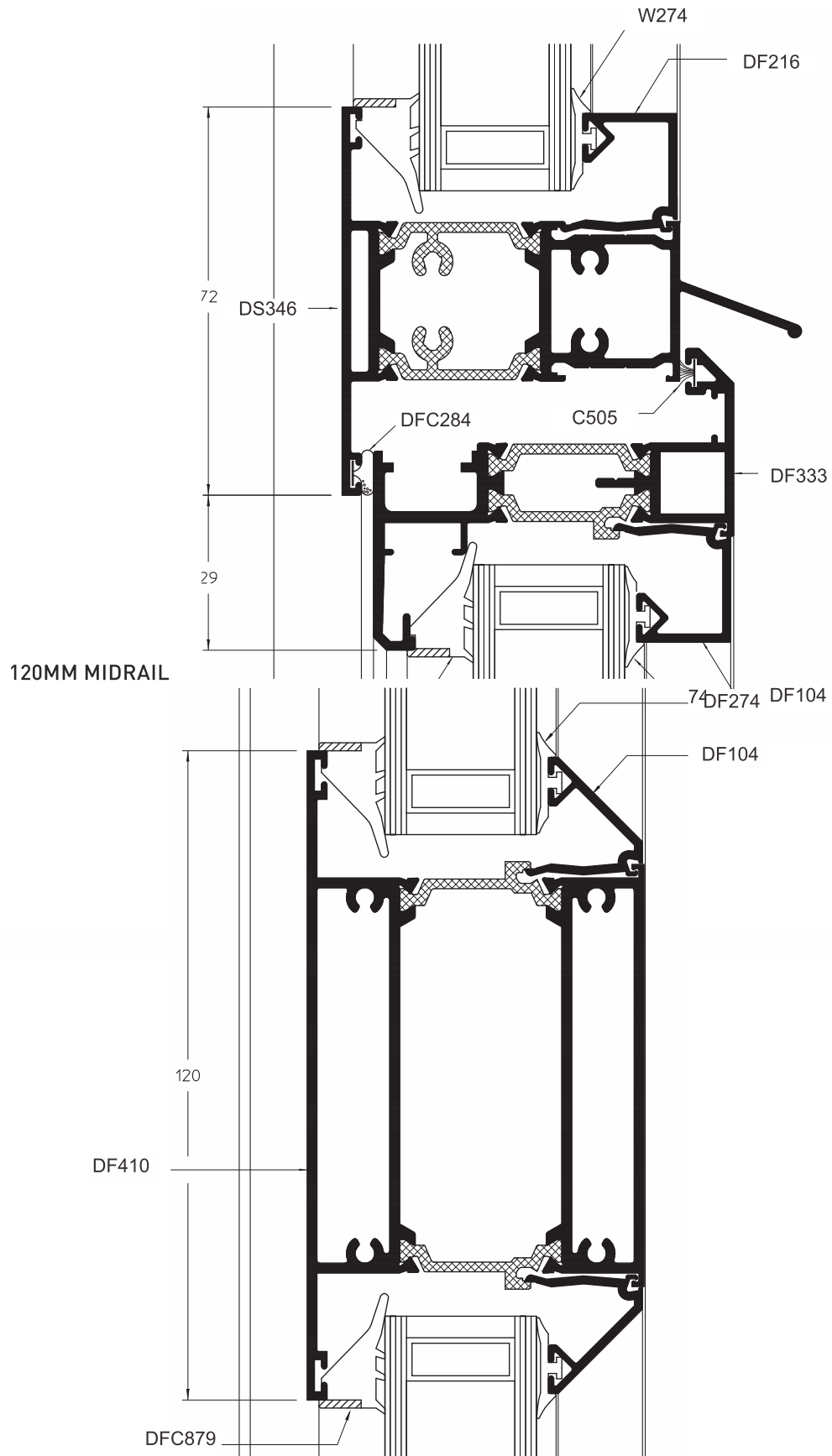

DUALFRAME

/GENERAL ARRANGEMENTS

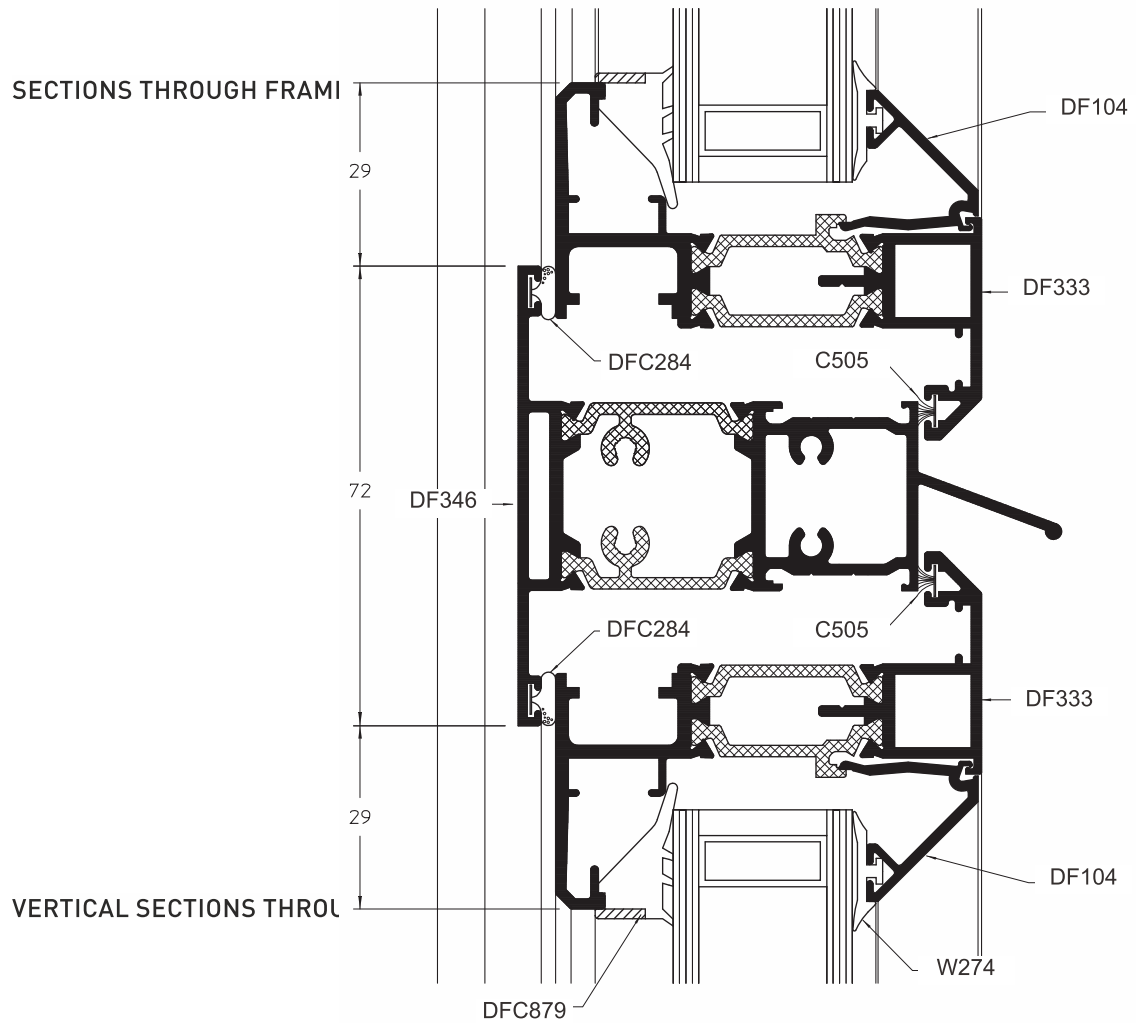

DUALFRAME

/UNIVERSAL PROFILES

CORNER POSTS

UF500
90° CORNER POST

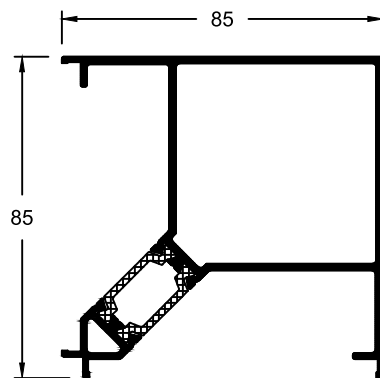

SUBCILLS

UF506
155MM SUBCILL

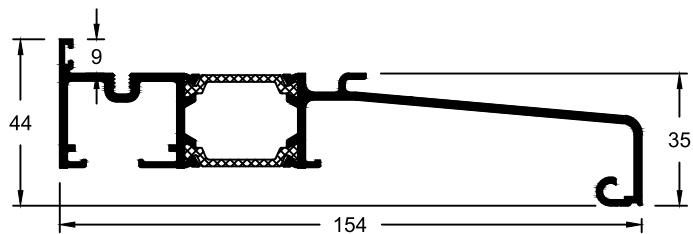

UF513
75MM PRESSING
SUBCILL

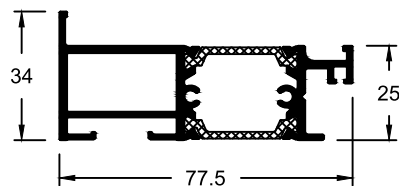

UF518
250MM SUBCILL

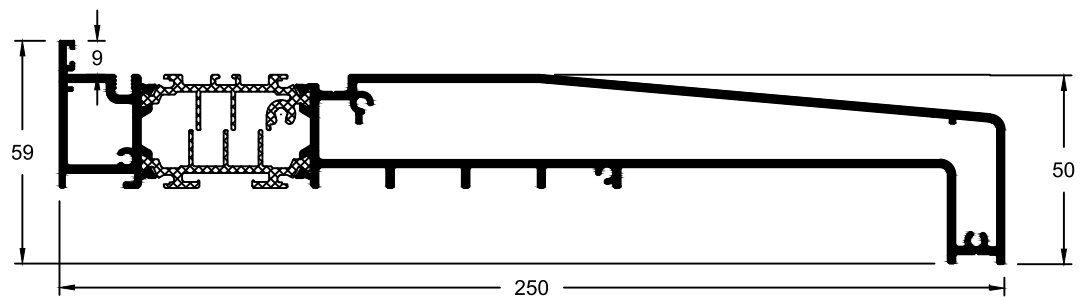

TRICKLE VENTS

UF508

TRICKLE VENT BODY

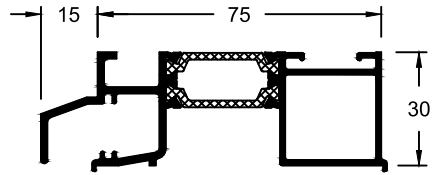

UF512

TRICKLE VENT BODY
(120MM FRAME)

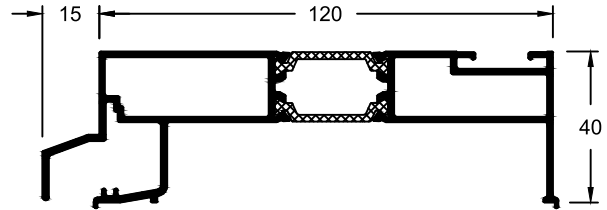

UF514

DEEP TRICKLE VENT
BODY

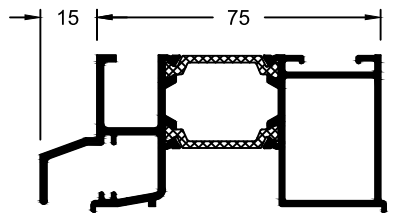

TRICKLE VENTS

UF510

FRAME EXTENDER
(15MM)

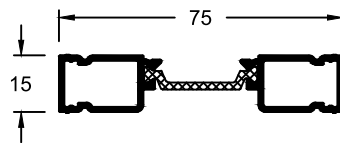

UF516

HEAD EXTENDER (40MM)

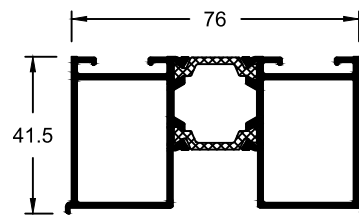

UF519

FRAME EXTENDER + LUG
FIX (15MM)

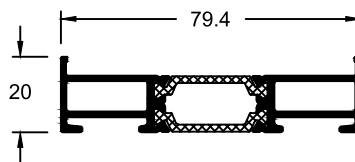



IMAGINE WHAT'S NEXT

Head Office
Severn Drive, Tewkesbury
Gloucestershire
GL20 8SF

Tel +44 1684 853500

Northern Office
Cedar Court Office Park,
Denby Dale Road, Wakefield
WF4 3FU

info.uk@technal.com

London Office
The Building Centre
26 Store Street, London
WC1E 7BT

www.technal.co.uk